

## Boedeker Plastics Case History

### Celazole® U-60 PBI Replaces Metal Valve Stem Bearing in 700°F Gas Turbine Safety Valve Application, Resulting in Significant Uptime.

#### Intro

In 2025, natural gas accounted for approximately 42% of the USA's power mix, making it the largest source of electricity production, surpassing coal, nuclear, and hydroelectric power as a single source. (Maguire, 2025) Its abundance, cost-effectiveness, lower emissions, and flexibility in meeting peak demand ensure its continued significance in electricity generation for the next decade.

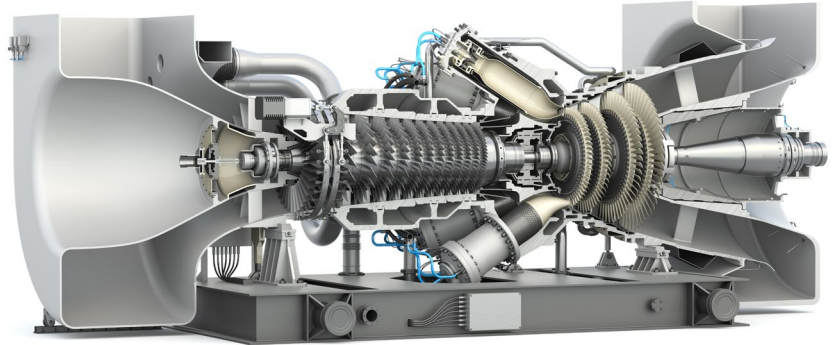

Gas turbines are essential for electricity production, converting natural gas or liquid fuels into mechanical energy, which powers generators in various applications, including power plants and military bases. Turbines have many safety features to prevent unsafe conditions or catastrophic failure. One of these safety mechanisms includes inline safety valves, which automatically release pressure if the turbine exceeds safe operating limits.

In this case history, we will examine how Celazole® U-60 PBI replaced metal in an in-line safety valve in a gas turbine application in the United States.

#### Challenge: Replace Metal Bearing Failure in Critical Safety Valve at 700° F

A metal valve stem bearing in a critical safety valve for a gas turbine failed within days of operation due to high temperatures (up to 700°F), causing grease breakdown and metal-on-metal wear. The failure, displayed in Figure 1, resulted in galling of the shaft and bearing, rendering the safety valve inoperable and raising safety concerns. The metal bearings were lasting for only a few days. The client was in need of a replacement material that could operate at high temperatures without the need for grease and extend the lifespan of the safety valve bearing.

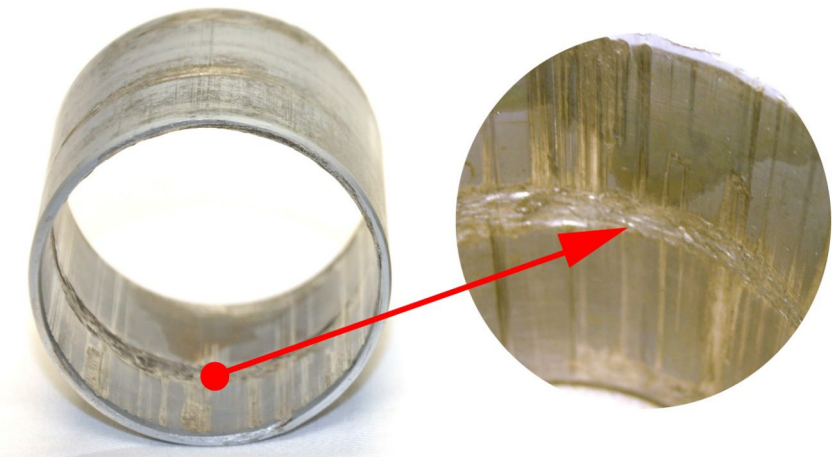

**Figure 1 – Metal Valve Stem Bearing Failure**  
*From metal-on-metal contact*

**Solution: Celazole® U-60 PBI Safety Valve Stem Bearing**

This valve stem bearing application faced extreme conditions, with operating temperatures reaching up to 700°F. It required a non-metallic material for an unlubricated bearing application to avoid metal-on-metal contact and prevent failures due to excessive wear. The replacement material had to provide excellent wear resistance and maintain high strength at elevated temperatures.

After reviewing the application parameters and available material options, Celazole® U-60 PBI was identified as the optimal material for metal replacement. It is recognized as the highest performing engineering plastic currently on the market. Celazole® U-60 PBI offers exceptional heat resistance, as it does not melt and retains working mechanical properties at temperatures of up to 800F (427C).

Figure 2 illustrates the dynamic mechanical analysis (DMA) comparing the relative modulus of Celazole® U-60 PBI, Celazole® TU-60 PBI/PEEK Blend, and unfilled PEEK. The DMA data indicates that Celazole® U-60 PBI maintains a high modulus even at 800°F (427°C).

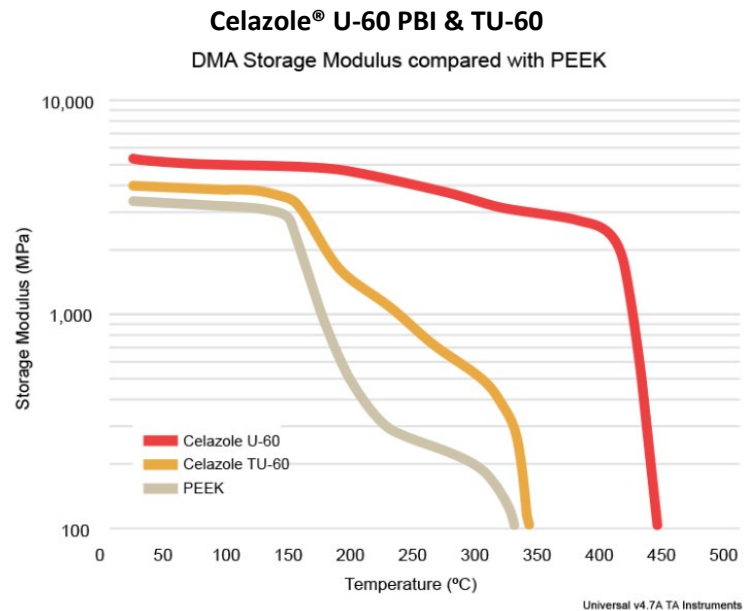

**Figure 2 - DMA Curve**  
Source: PBI Performance Products

**Result**

The Celazole® U-60 PBI safety valve stem bearing, illustrated in Figure 3, significantly increased the wear life of the metal bearing from just a few days to over a year. This improvement led to increased uptime, reduced maintenance costs, and enhanced safety, enabling the safety valve to function effectively whenever needed in the gas turbine application.



**Figure 3 – Celazole® U-60 PBI Metal Replacement Bearing**

**Reference**

Maguire, G. (2025, August 21). *Charting the projected US power capacity mix through 2035*. Reuters.com. Retrieved August 27, 2025, from <https://www.reuters.com/business/energy/charting-projected-us-power-capacity-mix-through-2035-2025-08-21>